

(No Model.)

J. MARTIGNONI.

MACHINE FOR CUTTING HELICAL GROOVES IN TWIST DRILLS.

No. 270,235.

Patented Jan. 9, 1883.

Fig. 1.

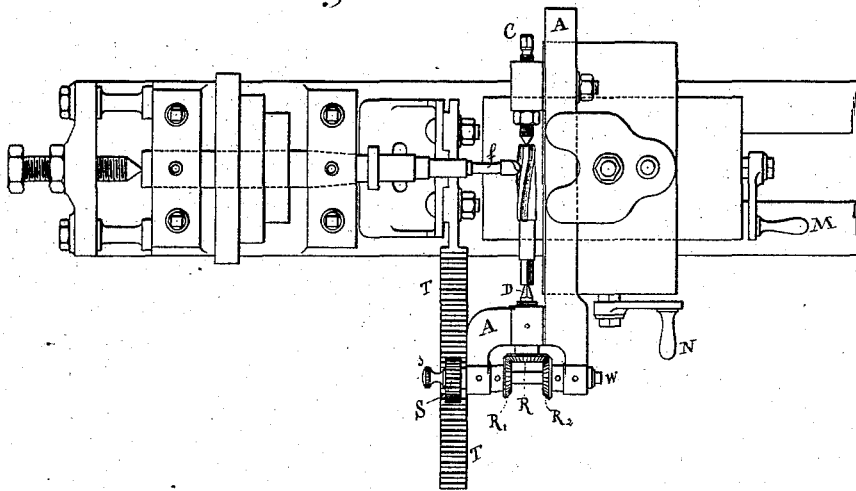

Fig. 2.

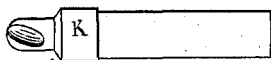

Fig. 3.



Witnesses.

C. Wetter
J. A. Rae

Inventor:

Johann Martignoni
per H. H. Hadden
Att'y.

UNITED STATES PATENT OFFICE.

JOHANN MARTIGNONI, OF BOCKENHEIM, NEAR FRANKFORT-ON-THE-MAIN,
GERMANY.

MACHINE FOR CUTTING HELICAL GROOVES IN TWIST-DRILLS.

SPECIFICATION forming part of Letters Patent No. 270,235, dated January 9, 1883.

Application filed September 20, 1882. (No model.) Patented in Germany January 27, 1882, No. 2,035; in Belgium January 23, 1882, No. 56,917; in France February 17, 1882, No. 147,412, and in England July 17, 1882, No. 3,334.

To all whom it may concern:

Be it known that I, JOHANN MARTIGNONI, of Bockenheim, near Frankfort-on-the-Main, in the Empire of Germany, have invented a new and useful Lathe Attachment for Cutting Helical Grooves in Twist-Drills and Similar Objects, (for which I have obtained patent in Germany, No. 2,035, bearing date 27th January, 1882; in Belgium, No. 56,917, bearing date 28th January, 1882; in France, No. 147,412, bearing date 17th of February, 1882, and in England a six months' provisional protection, No. 3,384, bearing date 17th July, 1882,) of which the following is a specification.

The apparatus which forms the object of my invention serves to cut twist-drills, reamers, screw-taps, and similar objects having helical grooves, and may be attached to an ordinary lathe. Its construction will be explained with the aid of the accompanying drawings, in which—

Figure 1 is a plan of a part of a lathe provided with the attachment, while Figs. 2 and 3 are respectively a side view and a front view of a cutting-tool.

The frame A A of the apparatus is fixed to the upper or cross slide of the lathe. The frame carries an adjustable screw, C, and a driver, D, with triangular extremity, forming a center, between which and the center of the screw C the piece of work is mounted.

Opposite the piece of work is placed the peculiarly-shaped cutter *f*, secured to the mandrel by means of a chuck. The object to be grooved is approached to the cutter *f* by turning the handle M of the slide.

The required helix is produced by a slow longitudinal and simultaneous slow rotary motion of the piece of work by means of the following mechanism: The pin D, which serves as a driver, carries at one extremity a bevel-wheel, R, and the contiguous end of the frame A A forms a forked bearing for the horizontal shaft W, on which are mounted the bevel-wheels R' and

R², gearing into the wheel R. On the same shaft is keyed outside the bearings a spur-wheel, S, which gears into a rack, T, bolted to the lathe-bed parallel to the piece of work. If the handle N is turned in order to move the lathe-slide so as to obtain a longitudinal motion of the piece of work, the pinion S, which gears into the stationary rack T, is forced to revolve, and transmits this motion to the bevel-wheel R by means of one of the bevel-wheels R' and R², mounted on the shaft W. Thereupon the wheel R turns the driver D, and consequently also the piece of work, on its axis. For cutting a right-hand helical groove, the right wheel R², and for cutting a left-hand groove the left wheel R', is screwed fast on its shaft, while the opposite wheel is loosened.

In order to render the helical groove more or less steep, the piece of work must be turned more rapidly or more slowly, which is effected by changing the spur-wheel S.

For producing straight grooves, the screw-caps, and subsequently the pinion S, is detached from the shaft W, while the rack T may or may not be detached from the lathe.

Having thus described my invention and the manner in which it may be used, I claim—

The combination, with the cross-slide of a lathe having the piece of work fixed thereto, of a driver, D, with bevel-wheel R, bevel-wheels R' R², and pinion S, a rack attached to the lathe and gearing into the said pinion for the purpose of producing a rotary motion of the pinion, driver, and piece of work when the cross-slide of the lathe is moved, substantially as described and illustrated.

In testimony whereof I have signed this specification in the presence of two subscribing witnesses.

JOHANN MARTIGNONI.

Witnesses:

ED. JULIUS JASSOG,
JEAN GRUND.